

## Gravimetric Blenders

The SGB series gravimetric blenders can be used in the fields of injection moulding machines, blow moulding machines and extrusion lines for proportionally precise mixing of several types of material. The machine is controlled by an advanced microprocessor with a digital display that is simple to calibrate. The self-compensation and calibration function ensure accurate material dosing percentages. A high precision electronic weighing scale is used to ensure precise weighing of every batch and ensure accuracy to  $\pm 0.1\%$ . Model selection should be based upon kinds of materials to be processed, with twelve models dosing capacity ranging from 40 kg/hr up to 600 kg/hr.

### Features:

- Even mixing of materials after accurately weighing.
- Advanced material dosing system precisely controls the weight of each material.
- Auto calibration of material weights ensures accuracy of material weighing.
- This machine has been designed for direct machine mount as standard. A machine mount base complete with magnets and manual slide gate is supplied as standard.
- Suitable for processing up to four(4) components simultaneously.
- All parts accessible for easy cleaning.
- Up to 56 recipes can be stored for later use.
- Supplied as standard, all components feeding into the weighing chamber are carried out by a pneumatic slide gate. For processing batch weight less than 50 grams, as optional feature, pneumatic slide gate should be replaced by Motor-driven Auger for better accuracy.
- In case of floor mount application, a combination of mobile floor stand, pneumatic slide gate, material storage bin and suction box shall be supplied as standard.



SGB-80-2  
(Machine Mount)



Motor-driven Auger  
(Option)



SGB-80-4-2R  
(Floor Mount)

## Outline Dimensions

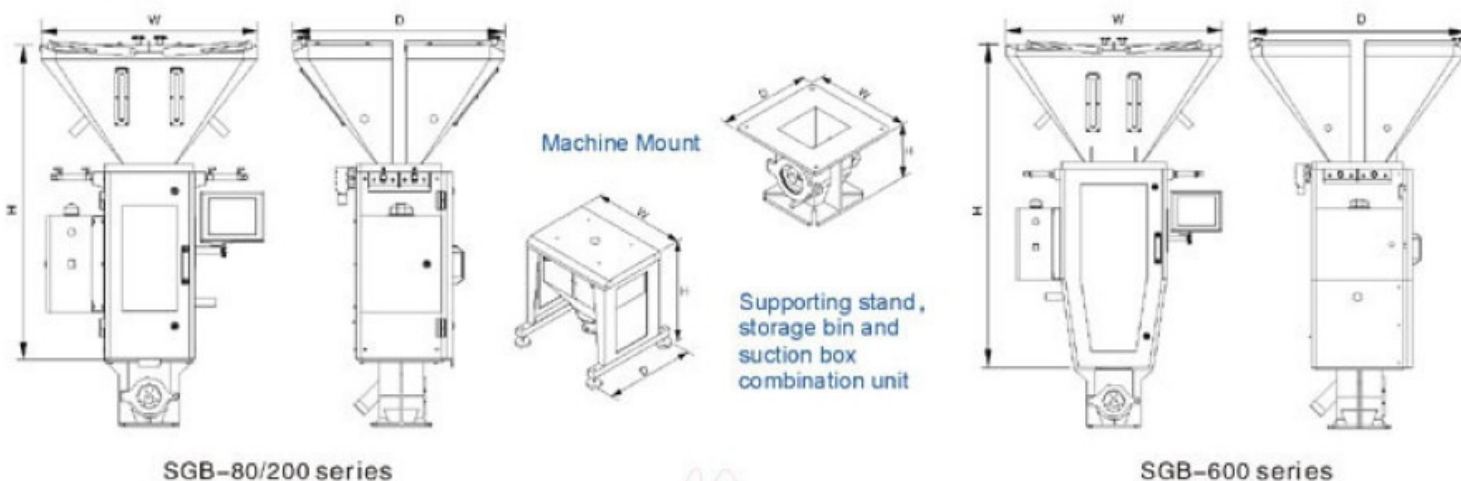

SGB-80/200 series

SGB-600 series

## Specifications

Model	SGB- 80-2	80-3	80-4	200-2	200-3	200-4	600-2	600-3	600-4
Max. Total Capacity (kg/hr)	80	80	80	200	200	200	600	600	600
Batch Handling Capacity (kg)	1.2	1.2	1.2	2.2	2.2	2.2	8	8	8
Compressed Air (kgf/cm <sup>2</sup> )	4-6	4-6	4-6	4-6	4-6	4-6	4-6	4-6	4-6
No. Of Hoppers	2	3	4	2	3	4	2	3	4
Hopper Capacity (L)	30	30	30	30	30	30	50	50	50
Blending Motor Power (kw, 50/60Hz)	0.18/0.2	0.18/0.2	0.18/0.2	0.18/0.2	0.18/0.2	0.18/0.2	0.37/0.44	0.37/0.44	0.37/0.44
Blending Motor Speed (rpm, 50/60Hz)	70/81	70/81	70/81	70/81	70/81	70/81	70/81	70/81	70/81
Weighting Chamber Volume (L)	6	6	6	8	8	8	20	20	20
Blending Chamber Capacity (L)	12	12	12	12	12	12	45	45	45
Main Power (V)	1Φ, 115/230V, 50/60Hz			1Φ, 115/230V, 50/60Hz			1Φ, 115/230V, 50/60Hz		
<b>Dimensions</b>									
H (mm)	1150			1150			1500		
W (mm)	790			790			1000		
D (mm)	770			770			1000		
Magnetic machine Mount Base (mm) (W×D×H)	245 × 325 × 310			245 × 385 × 310			345 × 360 × 420		
Mobile Floor Stand (mm) (W×D×H)	715 × 655 × 600			775 × 725 × 620			770 × 705 × 660		
VWeight (kg) (Machine Mount)	120			130			210		
VWeight (kg) (Floor Mount)	140			155			270		

Note: 1) "R" version is fitted with optional inductive motor driven device, for example SGB-80-4-1R, means four materials can be processed, one of those material discharging control is replaced by motor driven auger feed device.

2) All the output capacity from above models is base on the data from density 1.2 ,dia. 3-4mm pellets in a test criteria of continuous running.

We reserve the right to change specifications without prior notice.



MAQUINARIA  
PARA SOPLADO,  
INYECCIÓN  
Y EXTRUSIÓN  
DE TERMOPLÁSTICOS

[www.siepla.es](http://www.siepla.es)